

# CROSSOVER



"Our concept is an innovative 'Crossover' camper/caravan, providing a unique blend off road camper freedom and function with the comfort and security of a caravan."

## Not everything is created equal



# The new MS series suspension.

A hybrid, independent type comprising asymmetric lateral links each located by two unequal length longitudinal control arms.

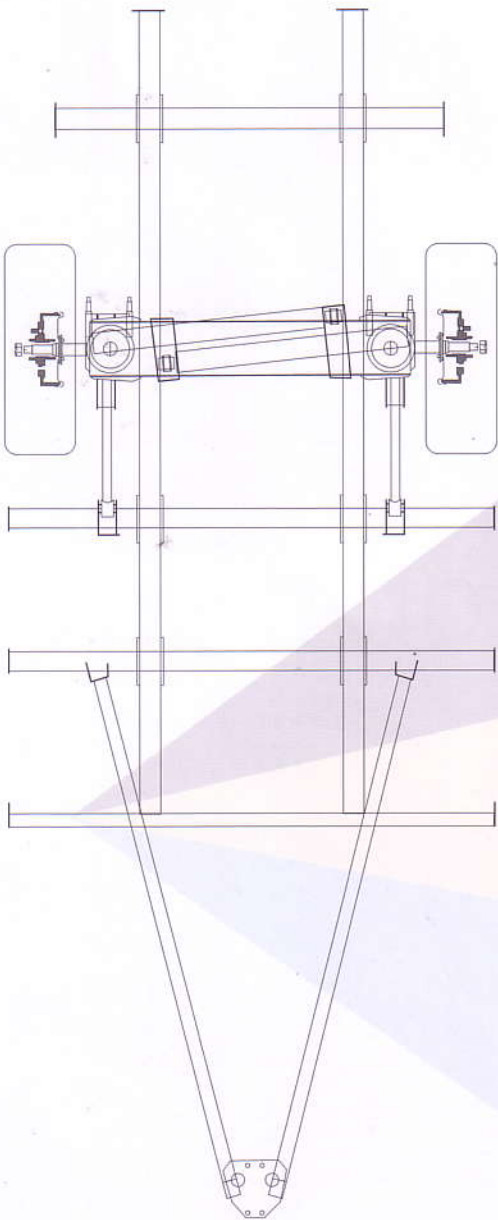
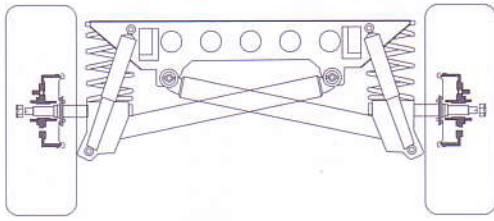

The MS Series suspension has been extensively tested.

It's smoother, it's soft but it's tough.

And has more wheel travel, an amazing (330mm/13")

It uses 10 (five per side) Neoprene rubber bushes encased in a metal jacket and centre mount, these will allow the control arms and asymmetric link to articulate up to 90 degrees.

These bushes are proven and tested over 1000's of kilometres across Australia and are used in serious off road vehicles.

The MS series suspension has not one fixed, but two bushed front unequal length control arms designed to keep the hub in a vertical plain keeping the shock absorber mounts parallel to each other, avoiding side and torsion load whilst working together delivering a smooth shock absorbing ride.

Our suspension design has a fully boxed cross member tying the two main chassis rails as part of a rigid construction also acting as a torsion box tube, The chassis has four torque tubes, three front and one rear of the suspension to maintain a rigid platform for the Vista Van.

Bump steer has been an inherent problem with previous lateral link types of suspension until now. The radical new geometry on our MS series suspension is designed to absorb change in weight load and will almost totally eliminate bump steer.

This is a great step forward from existing suspension systems, offering a more relaxing drive and peace of mind.

## Chassis System

Jig assembled and hot dip galvanized after fabrication. Lateral tube members interface with chassis rails via laser cut brackets to produce a torsionally rigid system.



# Vista RV Crossover is a single axle dedicated off road camper

## SPECIFICATIONS

### Exterior load provision

1. Front boot / toolbox	303 lt
2. Outside kitchen	70 lt
3. Front side locker	304 lt
4. Rear side locker Lower	110 lt
5. Rear side locker upper	103 lt
6. Battery locker and storage	98 lt
7. Gas bottles supplied	4.5KG x 2
8. Jerrycan holders	20 lt x 4
9. Water Tank	87 lt
Second tank option upgradable to	174 lt

### Inside load provisions

10. Electrical cupboard	31 lt
11. Sink cupboard	141 lt
12. Radio cupboard	39 lt
13. Robe	129 lt
14. Under seats	239 lt
15. Fridge	80 lt
16. Mesh pockets	4 off
17. Soft storage under Fridge	130 lt

### PHYSICAL SPECIFICATIONS

Length	4900 mm
Width	1900 mm
Height	2080 mm
Weight	1100 kg
Payload	400 kg
Ball weight	120 kg

#### Other Standard Items

- 100 amp hour deep cycle maintenance free gell battery
- Smart charge (automatic)
- Charging circuit to vehicle with anderson plug
- Two external 12 volt outlets and two internal auxiliary outlet
- All LED lighting
- Mp3 CD/Radio Stereo i pod and i pad ready
- 240 volt inlet and four internal outlets
- Triangular sail awning with End Wall fits on both sides
- Two rear recovery points
- Curtains
- Stone Bra
- Backup hand operated water pump

Specifications and notes on production models may vary in detail without notice in the interest in product improvements

## OPTIONS LIST



SOLAR PANEL OPTIONAL



FULL ANNEX AND ENSUITE



INNERSPRING MATTRESS



BATTERY UPGRADE 2 X 100 AMP GEL BATTERIES



EXTENDED DRAW BAR



FLY SCREEN & SIDE POCKETS



FULL COVER WITH ACCESS

## BODY DESIGN



OUTSIDE KITCHEN



80 LITRE FRIDGE



OUTSIDE HATCHES



DINETTE



QUEEN SIZE BED

# Crossover Family Pictures



Contact us

23C Jersey Road Bayswater, Victoria 3153

PH (03) 9729 1234 Fax (03) 9720 9200

[enquiries@vistarv.com.au](mailto:enquiries@vistarv.com.au)

ABN 93-140-834-046

[www.vistarv.com.au](http://www.vistarv.com.au)